

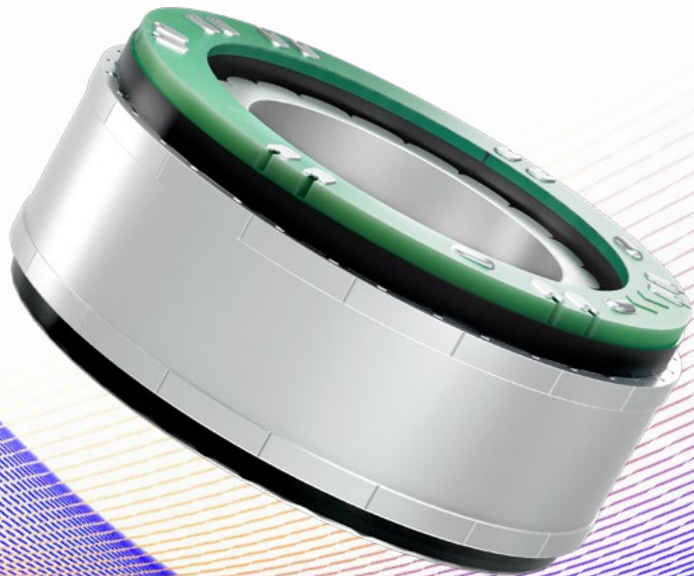

Delta Line

Moving together



Frameless Brushless DC Motors

2024/25 - Product Catalogue v1.24

Delta Line SA

Via Prè d'Ià 1
CH - 6814 Lamone
Switzerland

ph. +41 (0)91 612 85 00
fax. +41 (0)91 612 85 19

www.delta-line.com
info@delta-line.com

Delta Line North America, Inc

4600 South Syracuse, 9th Floor
Denver, CO 80237, USA

ph. +1 303 256 6212

www.delta-line.com
infous@delta-line.com



Frameless BLDC motors	Stator OD (mm)	Rotor ID (mm)	Stator height (mm)	Rated Torque (Nm)	
25BLF	25	11,6	5 9,2	0,032 0,063	9
38BLF	38	18	7 14	0,1 0,23	10
43BLF	43	25,5	8	0,15	11
50BLF	50	30	8,6 15	0,3 0,5	12
60BLF	60	39,2	12	0,45	13
70BLF	70	42	10 18,9	0,55 1	14
85BLF	85	52	13 23,8	1,2 2	15
102BLF	102	63	14	2,5	16
115BLF	115	74	25 50	3,9 7,8	17



Frameless Brushless DC Motors: Powering the Future with Precision

As industries continue to push the boundaries of design and performance, the demand for advanced motor technology is at an all-time high. Frameless Brushless DC motors are emerging as a critical solution in various applications requiring compactness, efficiency, and high torque density. At Delta Line, we are always at the forefront of technological innovation, striving to meet and exceed the demands of our customers by offering one of the most comprehensive ranges of motor technologies on the market. Our motors are designed with the highest quality standards to ensure optimal performance in even the most demanding environments.

Our range

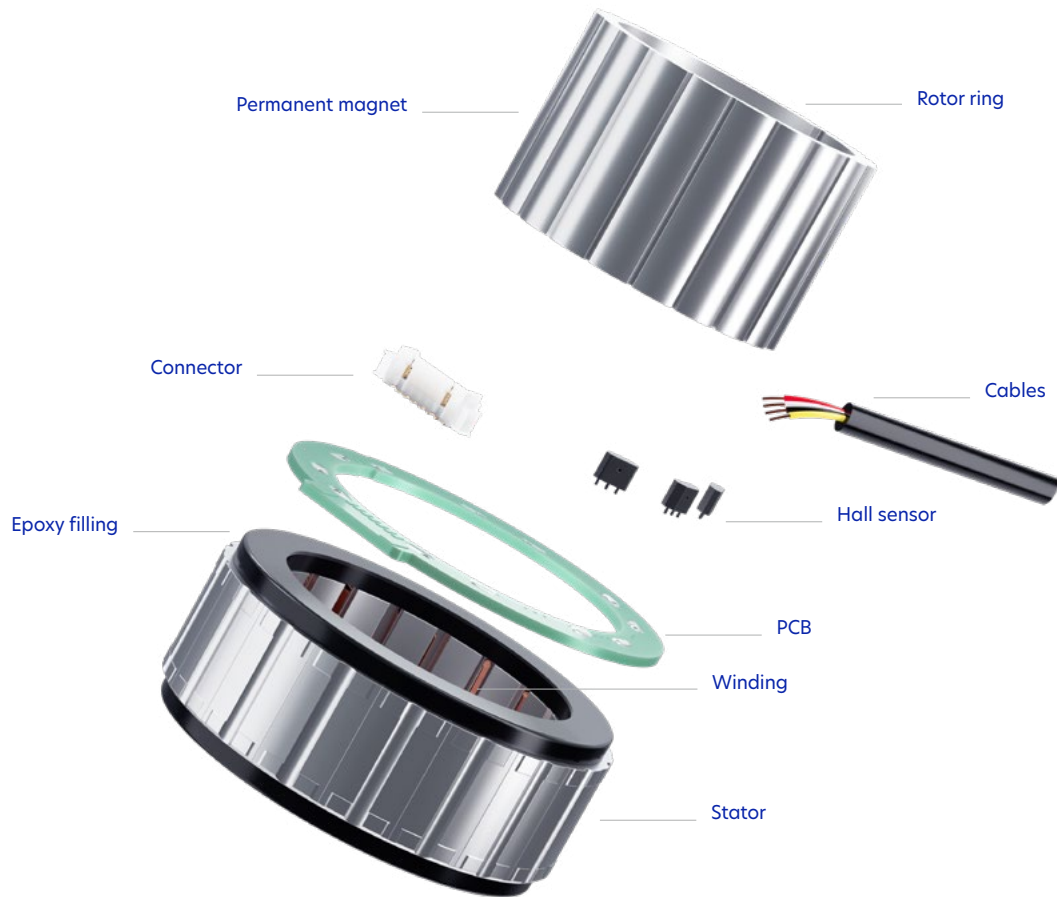

Easy to Integrate
Compact Design



Special arc-arc magnet design that allows for both high torque and very low cogging, achieved without the need for skewing. Our designs incorporate rare earth magnets in either a sintered or bonded format, dependent on motor construction and the needs of your application. The magnets are precisely placed and bonded to the rotor using a special technique that allows for high retention but is also forgiving on the airgap tolerance.

Proprietary Rotor and Magnet construction technique

Technical introduction

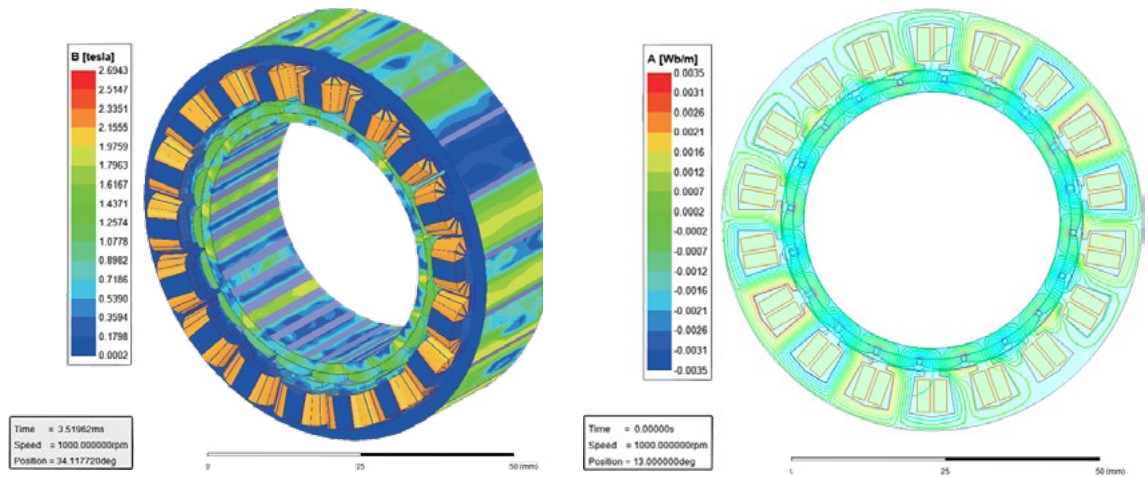

Designed to provide high torque density and low output cogging torque delivering smoother motion, more stable performance and longer operational life.

High Efficiency Stator Design: Multi-pole and Multi-slot



Epoxy filling of the stator leverages a high heat conductivity coefficient epoxy that provides optimized thermal management, realizing superior heat dissipation and lower temperature rise during operation.

Epoxy-filled finishing

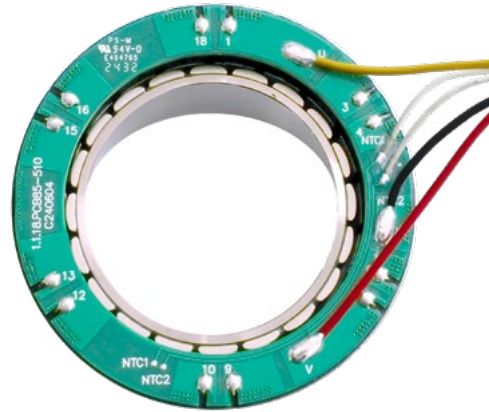

Standard

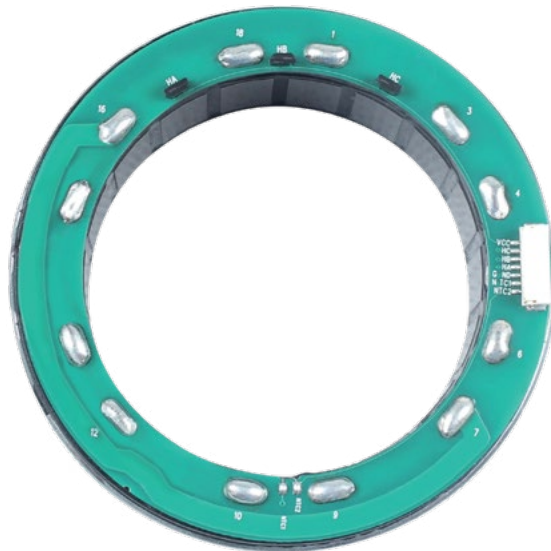

Optional

- **Hall Sensors:** for precise positioning and speed control
- **Thermistor:** for temperature monitoring
- **Connectors and Cabling:** various options are available on request and can be positioned to best suit your design
- **Winding Optimization:** for highest efficiency at the torque and speed points that are needed for your application

Delta Line understands the need for custom solutions to fully integrate into your design and we can offer you the above options on most of our Frameless Brushless DC motor range.

Our Motor Options



- _ Frameless motors used for **various size joints** within the robot, from small finger joints (25mm) to larger shoulder joints (85mm).
- _ Large rotor IDs that allow for **easy mounting** with gear reducers or passing cabling through
- _ **High efficiency** to allow for the greatest utilization of the battery pack
- _ Very **low cogging**, without sacrificing torque, to allow for smooth and natural motion

- _ Epoxy filled stator allows for **low external joint temperature** when sized properly
- _ High pole count motors allow for **quick reaction** to speed or torque commands, such as stopping motion when contacting an obstruction
- _ Wide range of stator ODs that **match most common strain wave gearboxes**
- _ Electromagnetic design offers exceptional velocity stability when paired with a capable controller

With their compact size, seamless integration, and high performance, Frameless motors unlock endless possibilities. Already widely used in:

- _ Humanoid Robots
- _ Collaborative Robotic Arms
- _ Exoskeletons
- _ LiDar systems

imagine how this technology could redefine many other applications, including yours.

Frameless Motor Applications

Term	
N. of pole	Areas of a motor where a magnetic pole is generated either by a permanent magnet or by passing current through the coils of a winding.
N. of phase	A group of electrically connected coils.
Rated Voltage	The voltage at which rated torque is generated with the motor at ambient temperature.
Rated Speed	The approximate motor speed at its rated torque point.
Max. speed	Is the maximum recommended speed based on thermal and mechanical perspectives. A reduced service life can be expected at higher speeds.
Rated Torque	The maximum torque, at rated speed, the motor can produce on a continuous basis, without exceeding the thermal rating of the motor.
Max. Peak Torque	The maximum torque a motor can produce for short periods of time, before irreversible demagnetization of the motor's magnets occurs.
Torque constant	The ratio of a motor's output torque to the motor's input power
Rated Current	The approximate amount of current the motor will draw at its rated torque point.
Max. Peak Current	The current drawn by the motor when delivering peak torque
No-Load Current	The current consumption of the motor at rated voltage and under no-load conditions. This value varies proportionally to speed and is influenced by temperature
Line to Line resistance	This is the phase resistance measured for the completed motor at room temperature. It includes solder, wire and (if present) connector resistances. In motors with very low resistance, the line to line resistance may differ significantly from the internal resistance.
Line to Line Inductance	This is the motor phase inductance measured with an inductance meter at 1000 Hz.
Rotor Inertia	Is the mass moment of inertia of the rotor, based on the axis of rotation.
Back EMF	The back (or counter) electromotive force (emf) E is the voltage generated by a running motor that acts to counter the supplied voltage.
Weight	Total motor mass.
Hall Effect angle	Phase angle at which hall sensors are positioned from each other.
Insulation class	The electrical insulation system for wires and other wire-wound electrical components is divided into different classes by temperature and temperature rise. The electrical insulation system is sometimes referred to as insulation class or thermal classification.
Dielectric strength	A dielectric test (also known as hipot or high potential test) is performed on all motors under 500V phases to the housing and during 5 seconds after voltage ramp up. Maximum allowed leakage is 1mA
Insulation resistance	The measurement of insulation resistance is carried out by means of a megohmmeter - high resistance range ohmmeter. DC voltage is applied between the windings and the ground of the motor.
Operating Ambient Temperature	Temperature range allowed for correct operation.
Humidity	Humidity range allowed for correct operation.

Glossary

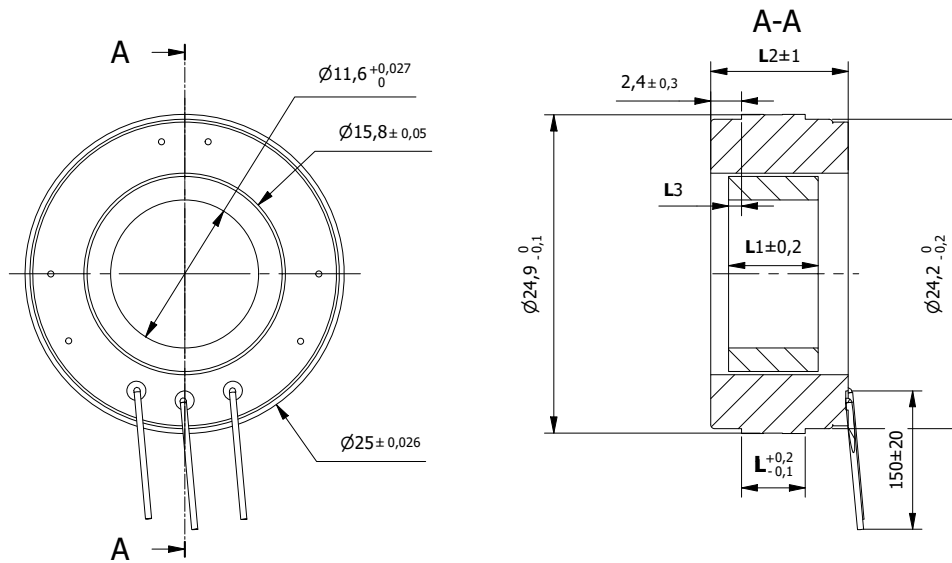

Optional: Thermistor

Specification			25BLF05	25BLF09
1	n° of Pole		14	14
2	n° of Phase		3	3
3	Rated Voltage	V	24	24
4	Rated Speed	rpm	10000	10000
5	Max. Speed	rpm	12300	13000
6	Rated Torque	Nm	0,032	0,063
7	Max. Peak Torque	Nm	0,105	0,204
8	Torque Constant	Nm/A	0,023	0,021
9	Rated Current	A	1,5	3
10	Max. Peak Current	A	5	9,8
11	No-Load Current	A	0,5	0,5
12	Line to Line Resistance	Ω	1,7	0,77
13	Line to Line Inductance	mH	0,6	0,28
14	Rotor Inertia	gcm ²	1,17	2,34
15	Back EMF	Vrms/Krpm	1,37	1,3
16	Stator height (L)	mm	5	9,2
17	Rotor height (L1)	mm	7	11
18	Length (L2)	mm	10,75	14,95
19	Measure (L3)	mm	1	0,9
20	Weight	g	18	28,5

Characteristics	
Item	
Hall Effect Angle	120°
Insulation Class	B 130°C
Dielectric strength (for 1 sec.)	600 VAC
Insulation Resistance (min. 500 VDC)	100 Mohm
Operating ambient temperature	-20°C to +50°C
Humidity	max. 85% not condensing

Connection		
Color	Gauge	Function
Red	AWG22	Phase U
White		Phase V
Black		Phase W

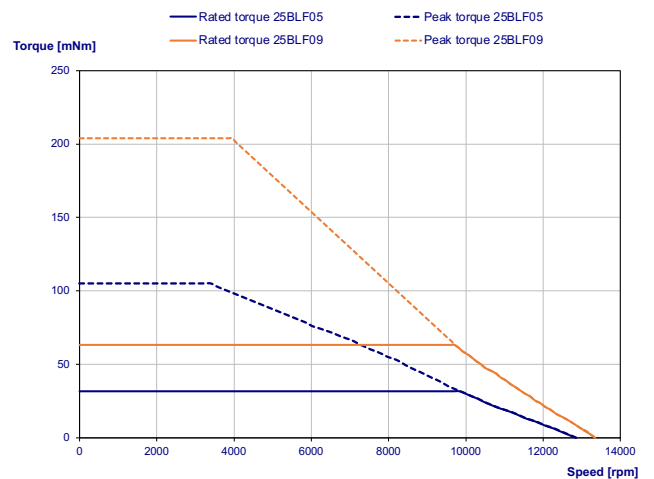

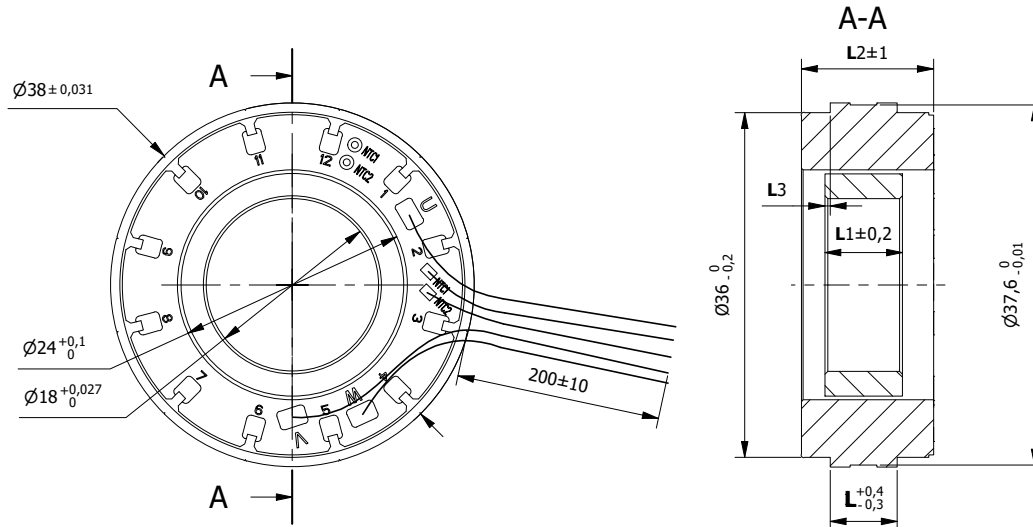

Optional: Thermistor

Specification			38BLF07	38BLF14
1	n° of Pole		14	14
2	n° of Phase		3	3
3	Rated Voltage	V	24	48
4	Rated Speed	rpm	8000	5000
5	Max. Speed	rpm	11000	7500
6	Rated Torque	Nm	0,1	0,23
7	Max. Peak Torque	Nm	0,3	0,69
8	Torque Constant	Nm/A	0,025	0,074
9	Rated Current	A	4,5	3,5
10	Max. Peak Current	A	13,5	10,5
11	No-Load Current	A	0,5	0,4
12	Line to Line Resistance	Ω	0,37	1,24
13	Line to Line Inductance	mH	0,32	1,3
14	Rotor Inertia	gcm ²	9,68	19,2
15	Back EMF	Vrms/Krpm	1,54	4,5
16	Stator height (L)	mm	7	14
17	Rotor height (L1)	mm	8,1	16,1
18	Length (L2)	mm	13,8	20,8
19	Measure (L3)	mm	0,55	1
20	Weight	g	57	112

Characteristics	
Item	
Hall Effect Angle	120°
Insulation Class	B 130°C
Dielectric strength (for 1 sec.)	600 VAC
Insulation Resistance (min. 500 VDC)	100 Mohm
Operating ambient temperature	-20°C to +50°C
Humidity	max. 85% not condensing

Connection		
Color	Gauge	Function
Yellow	AWG20	Phase U
Red		Phase V
Black		Phase W

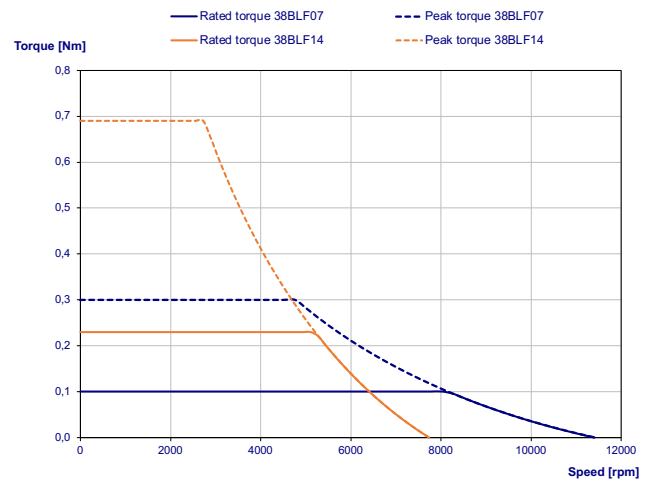

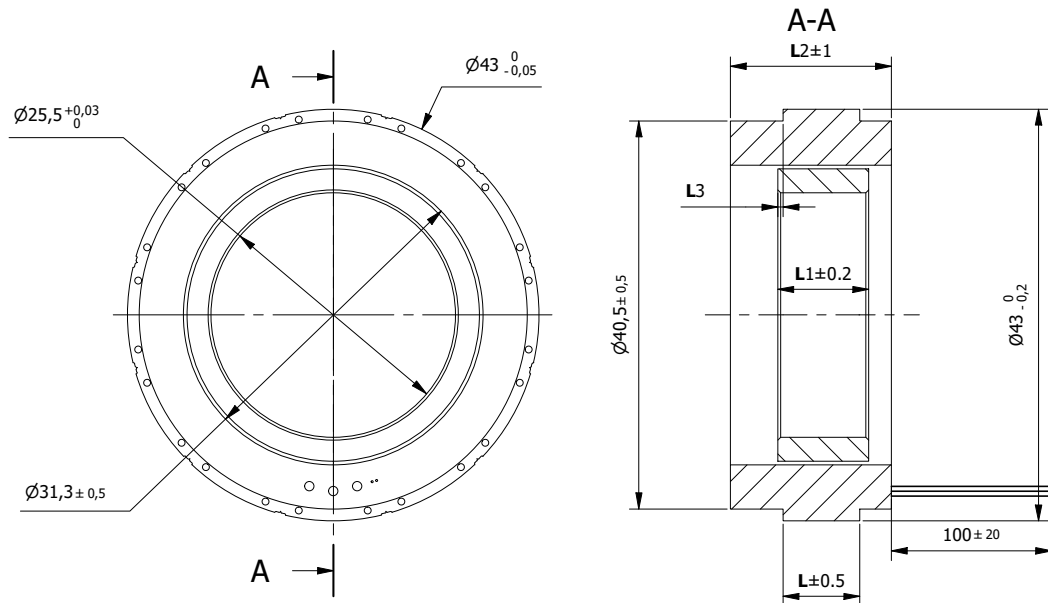

Optional: Thermistor

Specification		
Model	43BLF08	
1	n° of Pole	14
2	n° of Phase	3
3	Rated Voltage	V 48
4	Rated Speed	rpm 5000
5	Max. Speed	rpm 7300
6	Rated Torque	Nm 0,15
7	Max. Peak Torque	Nm 0,45
8	Torque Constant	Nm/A 0,077
9	Rated Current	A 2
10	Max. Peak Current	A 6
11	No-Load Current	A 0,4
12	Line to Line Resistance	Ω 2,8
13	Line to Line Inductance	mH 1,8
14	Rotor Inertia	gcm ² 27
15	Back EMF	Vrms/Krpm 4,65
16	Stator height (L)	mm 8
17	Rotor height (L1)	mm 9,5
18	Length (L2)	mm 16,8
19	Measure (L3)	mm 0,5
20	Weight	g 70

Characteristics	
Item	
Hall Effect Angle	120°
Insulation Class	B 130°C
Dielectric strength (for 1 sec.)	650 VAC
Insulation Resistance (min. 500 VDC)	100 Mohm
Operating ambient temperature	-20°C to +50°C
Humidity	max. 85% not condensing

Connection		
Color	Gauge	Function
Yellow	AWG24	Phase U
Red		Phase V
Black		Phase W

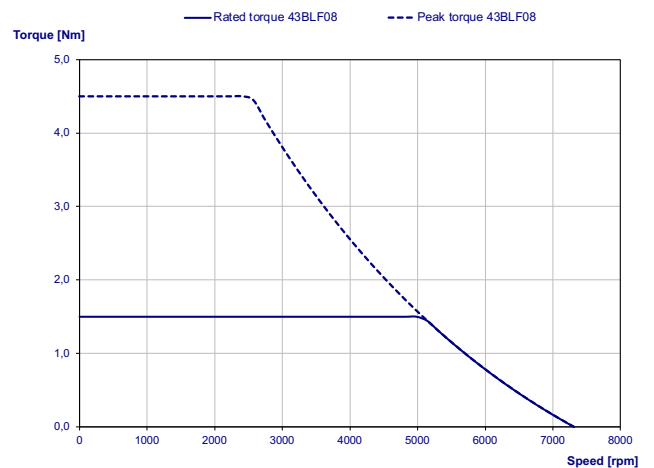

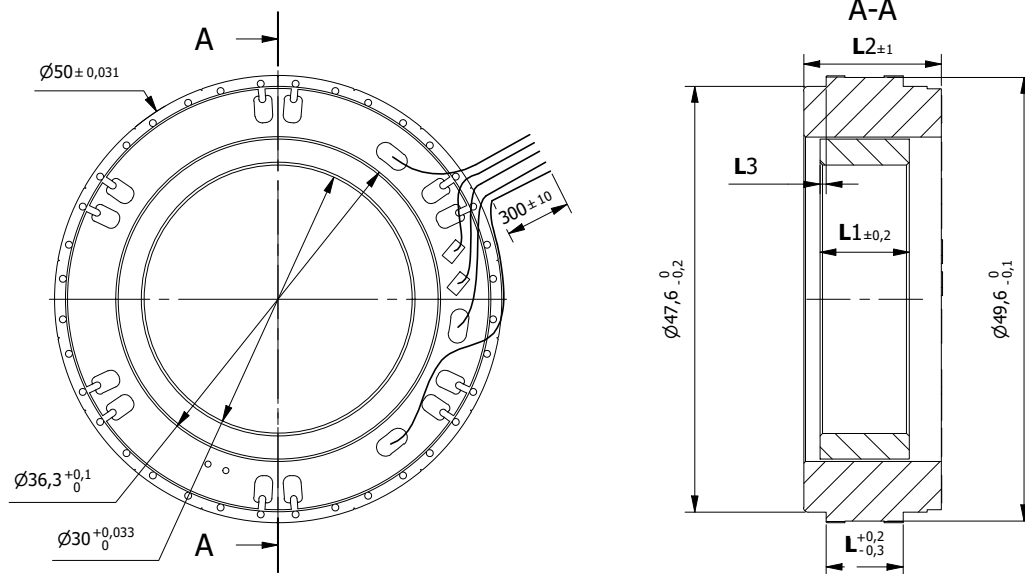

Optional: Hall sensors, Thermistor and PCB mounted Connector

Specification			
	Model	50BLF08	50BLF15
1	n° of Pole	20	20
2	n° of Phase	3	3
3	Rated Voltage	V	48
4	Rated Speed	rpm	5000
5	Max. Speed	rpm	6200
6	Rated Torque	Nm	0,3
7	Max. Peak Torque	Nm	0,96
8	Torque Constant	Nm/A	0,089
9	Rated Current	A	3,6
10	Max. Peak Current	A	11,6
11	No-Load Current	A	0,4
12	Line to Line Resistance	Ω	0,93
13	Line to Line Inductance	mH	0,46
14	Rotor Inertia	gcm ²	56,36
15	Back EMF	Vrms/Krpm	5,4
16	Stator height (L)	mm	8,6
17	Rotor height (L1)	mm	10
18	Length (L2)	mm	15,4
19	Measure (L3)	mm	0,7
20	Weight	g	105

Characteristics	
Item	
Hall Effect Angle	120°
Insulation Class	B 130°C
Dielectric strength (for 1 sec.)	1000 VAC
Insulation Resistance (min. 500 VDC)	100 Mohm
Operating ambient temperature	-20°C to +50°C
Humidity	max. 85% not condensing

Connection		
Color	Gauge	Function
Yellow	AWG22/20	Phase U
Red		Phase V
Black		Phase W

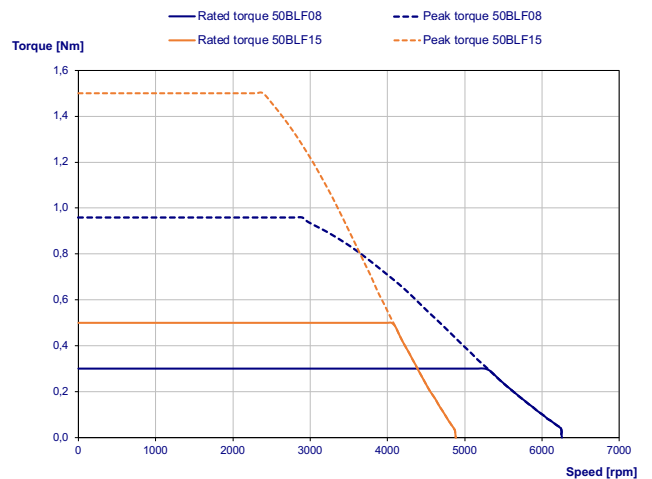

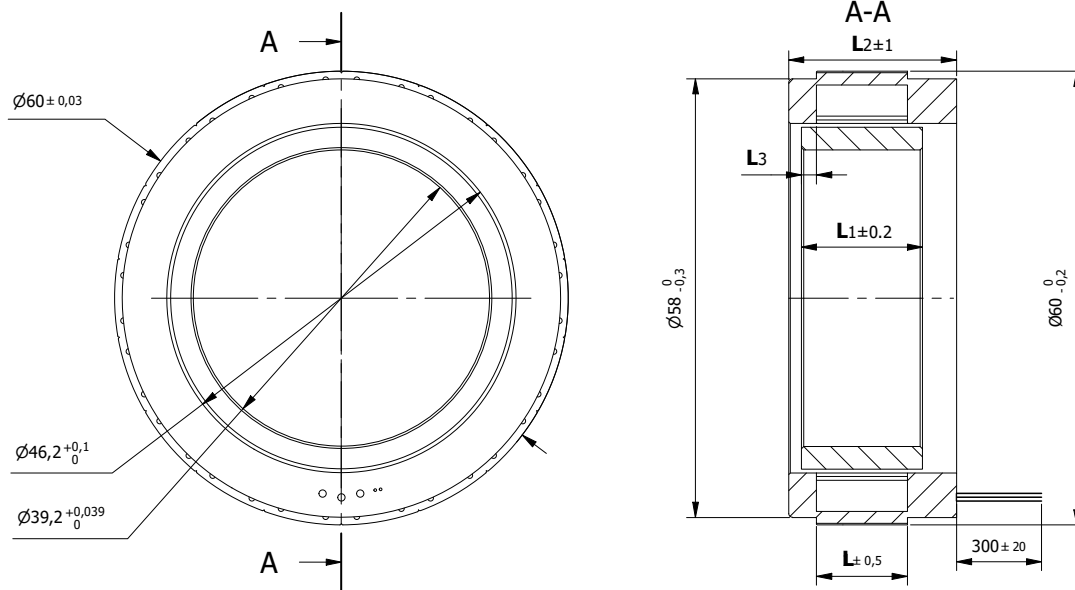

Optional: Hall sensors, Thermistor and PCB mounted Connector

Specification		
Model	60BLF12	
1	n° of Pole	20
2	n° of Phase	3
3	Rated Voltage	V 48
4	Rated Speed	rpm 4000
5	Max. Speed	rpm 5200
6	Rated Torque	Nm 0,45
7	Max. Peak Torque	Nm 1,35
8	Torque Constant	Nm/A 0,102
9	Rated Current	A 5
10	Max. Peak Current	A 15
11	No-Load Current	A 2
12	Line to Line Resistance	Ω 0,62
13	Line to Line Inductance	mH 0,46
14	Rotor Inertia	gcm ² 172
15	Back EMF	Vrms/Krpm 6,2
16	Stator height (L)	mm 12
17	Rotor height (L1)	mm 16
18	Length (L2)	mm 22,2
19	Measure (L3)	mm 2
20	Weight	g 165

Characteristics	
Item	
Hall Effect Angle	120°
Insulation Class	B 130°C
Dielectric strength (for 1 sec.)	650 VAC
Insulation Resistance (min. 500 VDC)	100 Mohm
Operating ambient temperature	-20°C to +50°C
Humidity	max. 85% not condensing

Connection		
Color	Gauge	Function
Yellow	AWG20	Phase U
Red		Phase V
Black		Phase W

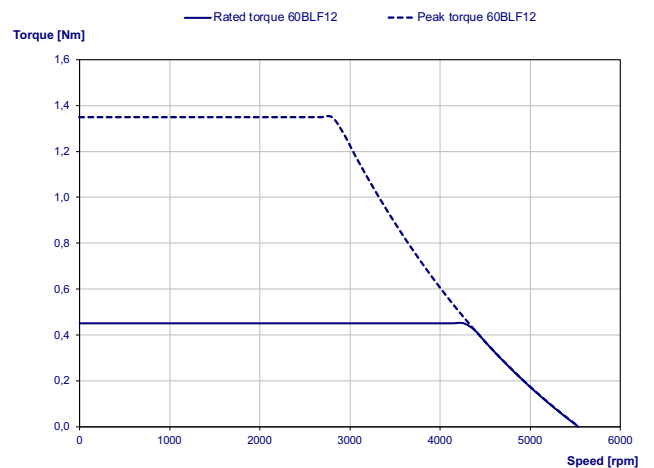

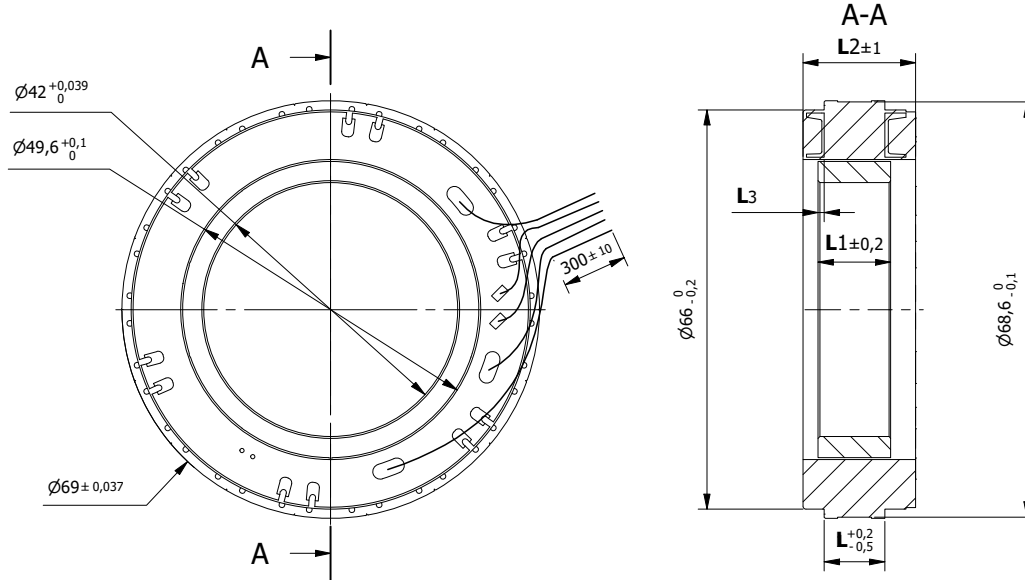

Optional: Hall sensors, Thermistor and PCB mounted Connector

Specification			70BLF10	70BLF19
1	n° of Pole		20	20
2	n° of Phase		3	3
3	Rated Voltage	V	48	48
4	Rated Speed	rpm	3650	3500
5	Max. Speed	rpm	4750	4500
6	Rated Torque	Nm	0,55	1
7	Max. Peak Torque	Nm	1,65	3
8	Torque Constant	Nm/A	0,118	0,12
9	Rated Current	A	5,1	9
10	Max. Peak Current	A	15,5	27
11	No-Load Current	A	0,4	0,6
12	Line to Line Resistance	Ω	0,36	0,19
13	Line to Line Inductance	mH	0,33	0,18
14	Rotor Inertia	gcm ²	215	376
15	Back EMF	Vrms/Krpm	7,14	7,2
16	Stator height (L)	mm	10	18,9
17	Rotor height (L1)	mm	12	21
18	Length (L2)	mm	18,6	27
19	Measure (L3)	mm	1	1
20	Weight	g	189	296

Characteristics	
Item	
Hall Effect Angle	120°
Insulation Class	B 130°C
Dielectric strength (for 1 sec.)	1000 VAC
Insulation Resistance (min. 500 VDC)	100 Mohm
Operating ambient temperature	-20°C to +50°C
Humidity	max. 85% not condensing

Connection		
Color	Gauge	Function
Yellow	AWG20/18	Phase U
Red		Phase V
Black		Phase W

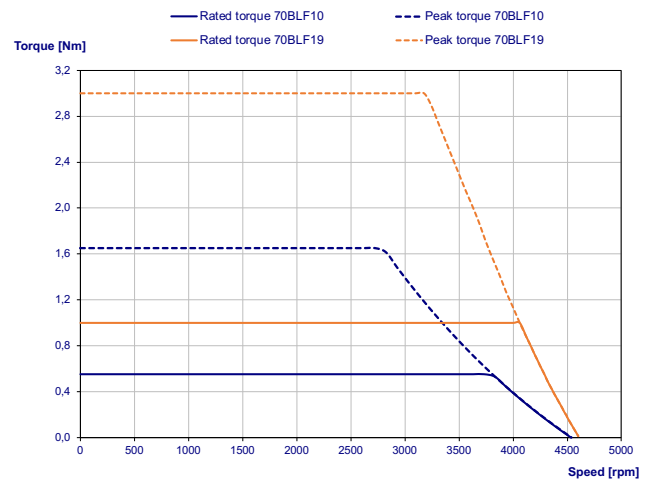

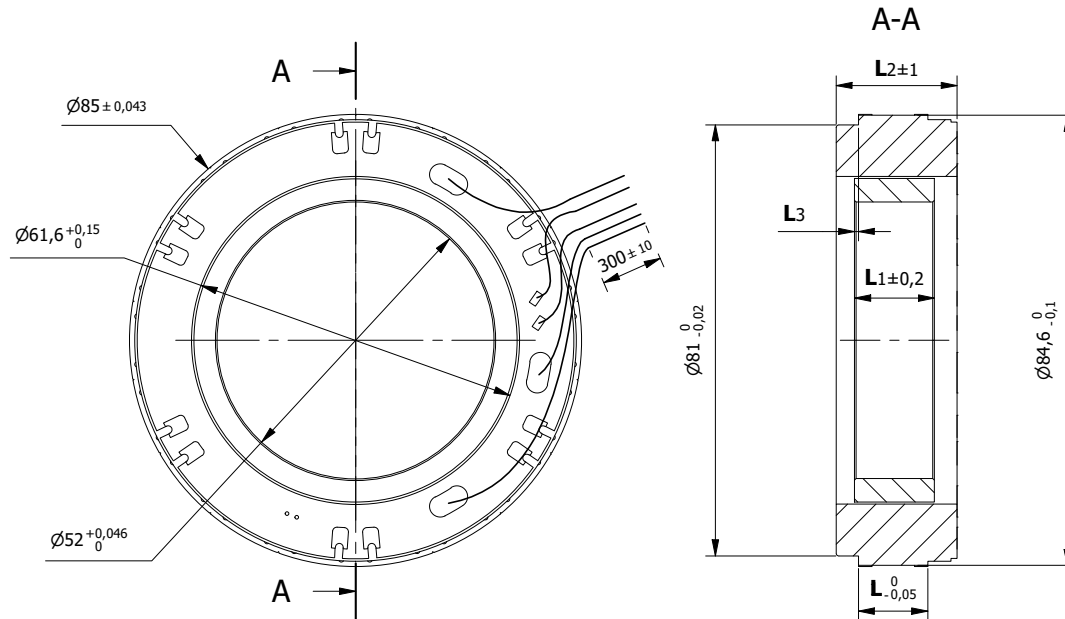

Optional: Hall sensors, Thermistor and PCB mounted Connector

Specification			85BLF13	85BLF23
1	n° of Pole		20	20
2	n° of Phase		3	3
3	Rated Voltage	V	48	48
4	Rated Speed	rpm	2950	3500
5	Max. Speed	rpm	3700	4000
6	Rated Torque	Nm	1,2	2
7	Max. Peak Torque	Nm	3,6	6
8	Torque Constant	Nm/A	0,143	0,13
9	Rated Current	A	9	16,5
10	Max. Peak Current	A	27	49,5
11	No-Load Current	A	0,6	1,1
12	Line to Line Resistance	Ω	0,21	0,09
13	Line to Line Inductance	mH	0,3	0,12
14	Rotor Inertia	gcm ²	646	1079
15	Back EMF	Vrms/Krpm	8,7	8,1
16	Stator height (L)	mm	13	23,8
17	Rotor height (L1)	mm	15	25
18	Length (L2)	mm	22,7	32,7
19	Measure (L3)	mm	0,7	0,6
20	Weight	g	346	554

Characteristics	
Item	
Hall Effect Angle	120°
Insulation Class	B 130°C
Dielectric strength (for 1 sec.)	1000 VAC
Insulation Resistance (min. 500 VDC)	100 Mohm
Operating ambient temperature	-20°C to +50°C
Humidity	max. 85% not condensing

Connection		
Color	Gauge	Function
Yellow	AWG18/16	Phase U
Red		Phase V
Black		Phase W

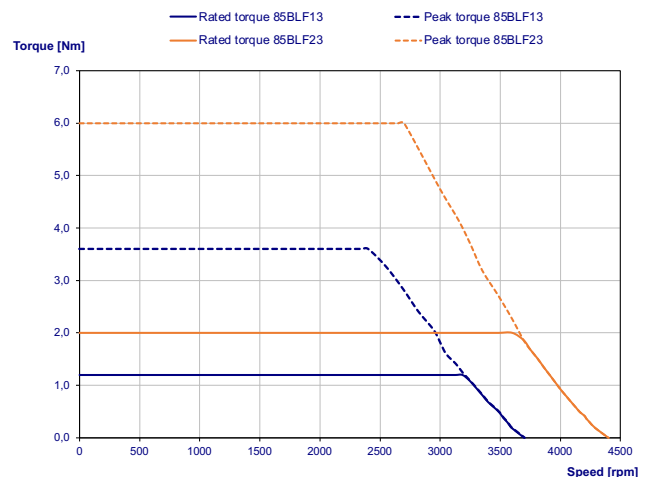

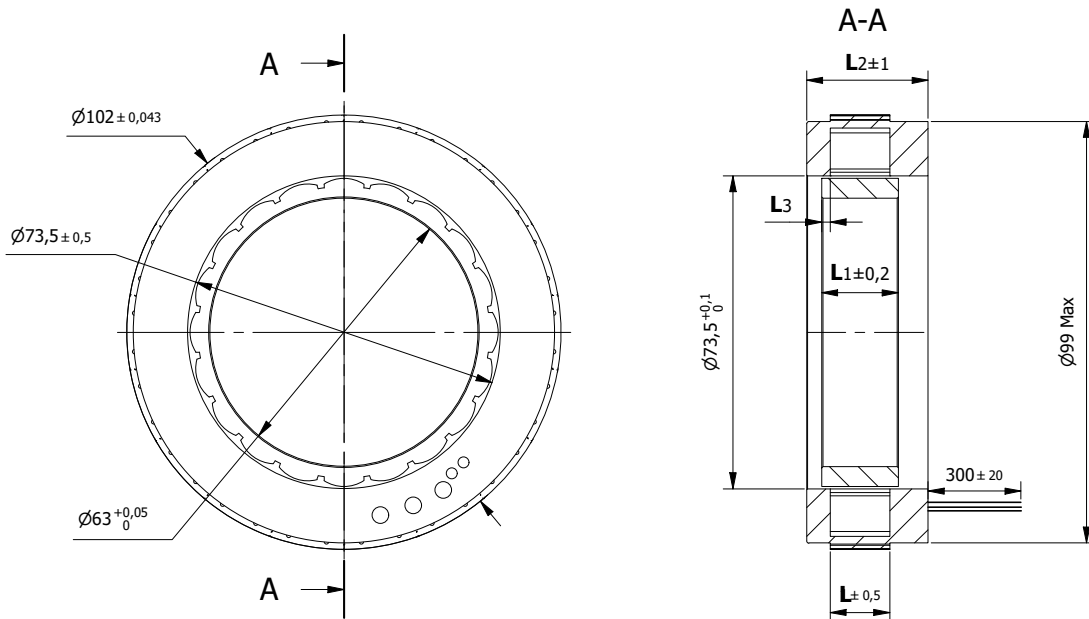

Optional: Hall sensors, Thermistor and PCB mounted Connector

Specification		
Model	102BLF14	
1	n° of Pole	20
2	n° of Phase	3
3	Rated Voltage	V 48
4	Rated Speed	rpm 2000
5	Max. Speed	rpm 3100
6	Rated Torque	Nm 2,5
7	Max. Peak Torque	Nm 7,5
8	Torque Constant	Nm/A 0,182
9	Rated Current	A 15,8
10	Max. Peak Current	A 44,4
11	No-Load Current	A 1,5
12	Line to Line Resistance	Ω 0,157
13	Line to Line Inductance	mH 0,555
14	Rotor Inertia	gcm ² 1375
15	Back EMF	Vrms/Krpm 11,05
16	Stator height (L)	mm 14
17	Rotor height (L1)	mm 18
18	Length (L2)	mm 28,5
19	Measure (L3)	mm 2
20	Weight	g 608

Characteristics	
Item	
Hall Effect Angle	120°
Insulation Class	B 130°C
Dielectric strength (for 1 sec.)	650 VAC
Insulation Resistance (min. 500 VDC)	100 Mohm
Operating ambient temperature	-20°C to +50°C
Humidity	max. 85% not condensing

Connection		
Color	Gauge	Function
Yellow	AWG16	Phase U
Red		Phase V
Black		Phase W

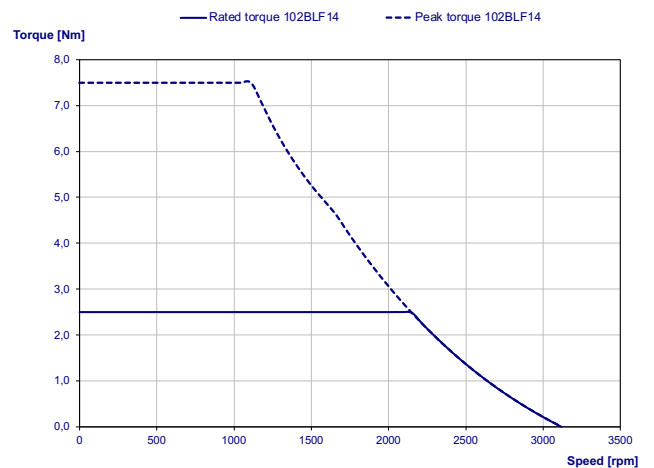

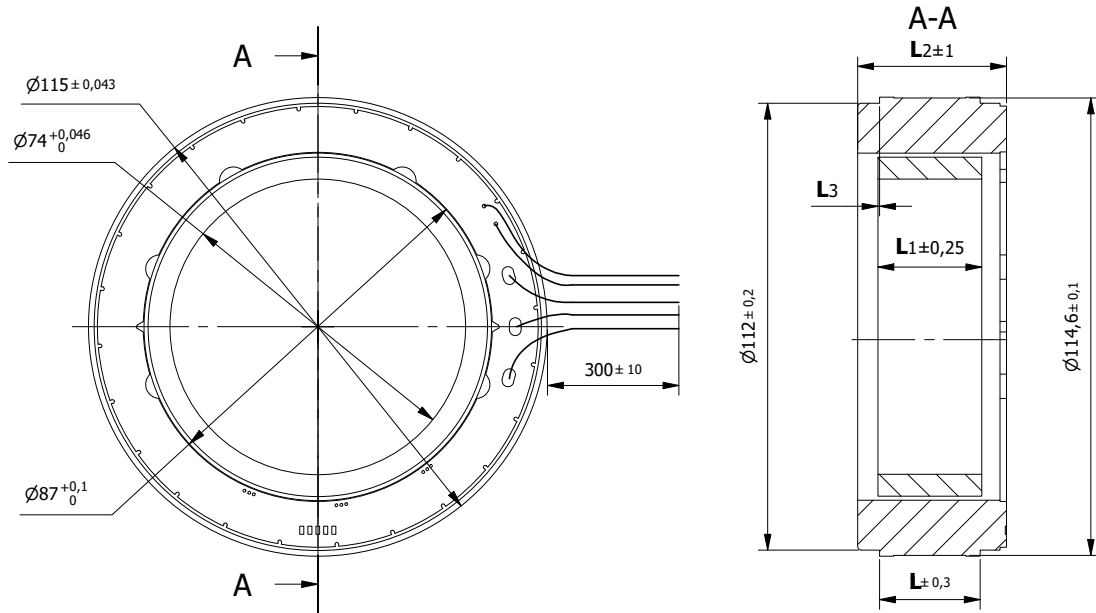

Optional: Hall sensors, Thermistor and PCB mounted Connector

Specification			115BLF25	115BLF50
1	n° of Pole		20	20
2	n° of Phase		3	3
3	Rated Voltage	V	48	48
4	Rated Speed	rpm	1400	620
5	Max. Speed	rpm	1900	900
6	Rated Torque	Nm	3,9	7,8
7	Max. Peak Torque	Nm	11,7	23,4
8	Torque Constant	Nm/A	0,293	0,662
9	Rated Current	A	14,1	13
10	Max. Peak Current	A	42,3	39
11	No-Load Current	A	1,4	1,3
12	Line to Line Resistance	Ω	0,2	0,35
13	Line to Line Inductance	mH	0,5	1,6
14	Rotor Inertia	gcm ²	4120	9100
15	Back EMF	Vrms/Krpm	17,7	40
16	Stator height (L)	mm	25	50
17	Rotor height (L1)	mm	26	51
18	Length (L2)	mm	37,3	62,1
19	Measure (L3)	mm	0,4	0,5
20	Weight	g	1100	2000

Characteristics	
Item	
Hall Effect Angle	120°
Insulation Class	B 130°C
Dielectric strength (for 1 sec.)	1000 VAC
Insulation Resistance (min. 500 VDC)	100 Mohm
Operating ambient temperature	-20°C to +50°C
Humidity	max. 85% not condensing

Connection		
Color	Gauge	Function
Yellow	AWG12	Phase U
Red		Phase V
Black		Phase W

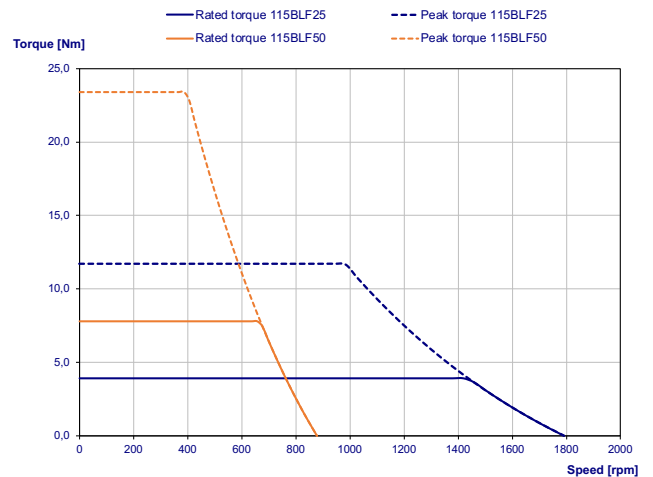

To see our full range
please visit our website:



www.delta-line.com



- _ Coreless
- _ PMDC

Brushed DC Motors
Ø 8-63mm



- _ Slotted & Slotless
- _ Flat
- _ Frameless
- _ with encoder

Brushless DC Motors
Ø 10-115 mm

Motors



- _ for Stepper motors
- _ for Brushless motors

Controllers / Drives
Phase current 2 to 40A rms



- _ Speed Controller
- _ Motion Controller

**BLDC, Servo &
Stepper with Controller**
Ø 16-80mm / □ 42-86mm

Electronics

Our technologies



- _ Medium voltage 220VAC
- _ Low voltage 48VDC

Servomotors

□ 38-130mm

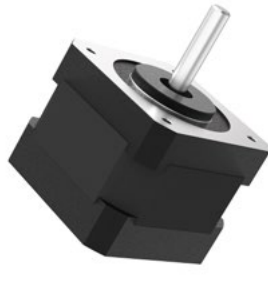

- _ Hybrid
- _ Flat
- _ Hollow shaft
- _ with encoder

Stepper Motors

Nema 6-42 Ø 14-110mm



- _ External
- _ Captive
- _ Non-Captive

Linear Actuators

Nema 8-23



- _ Planetary
- _ Spur

Gearboxes

Ø 8-80mm

Gearboxes



- _ Standard variations
- _ Modular assembly
- _ Full custom

Customizations

Custom

Delta Line SA

Via Prè d'Ià 1
CH - 6814 Lamone
Switzerland

ph. +41 (0)91 612 85 00
fax. +41 (0)91 612 85 19

www.delta-line.com
info@delta-line.com

Delta Line North America, Inc

4600 South Syracuse, 9th Floor
Denver, CO 80237, USA

ph. +1 303 256 6212

www.delta-line.com
infous@delta-line.com

